

T:1.6 Dimensions of PC board holes
Tolerance : ±0.1(Printed-top view)

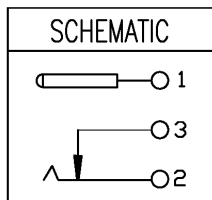
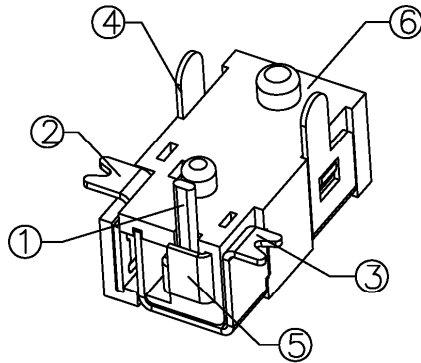

Item	Name	Material	Finish
1	Pin	H59 (copper)	MB:Ni Ag Plated
2	Tip Spring	C5191 t=0.25	MB:Ni Ag Plated
3	Shunt Terminal	C2680 t=0.25	MB:Ni Ag Plated
4	Terminal	C2680 t=0.20	MB:Ni Ag Plated
5	Terminal	SUS301 t=0.20	MB:Ni Ag Plated
6	Housing	PA9T	UL-94V0 (Black)

RoHS compliant

Rev.	Description	Date	Approved	Drawing	Name	Date
				Approved	Howard	04/16/09
				Checked	Lizzy	04/16/09
				Drawn	Tina	04/16/09
				0.0 ± 0.35	0.00 ± 0.20	Angles ± 3'
				UNIT: mm		

Central Components Manufacturing
 440 Lincoln Blvd., Middlesex, New Jersey 08846
 Phone 732 469-5720 888 288-5152 Fax 732 469-1919

Part No.: **DCJ-240B-S-SMT**

Description: DC Power Jack