

SPECIFICATIONS

Material:
Finish:

Zinc Alloy
Chromate Plating

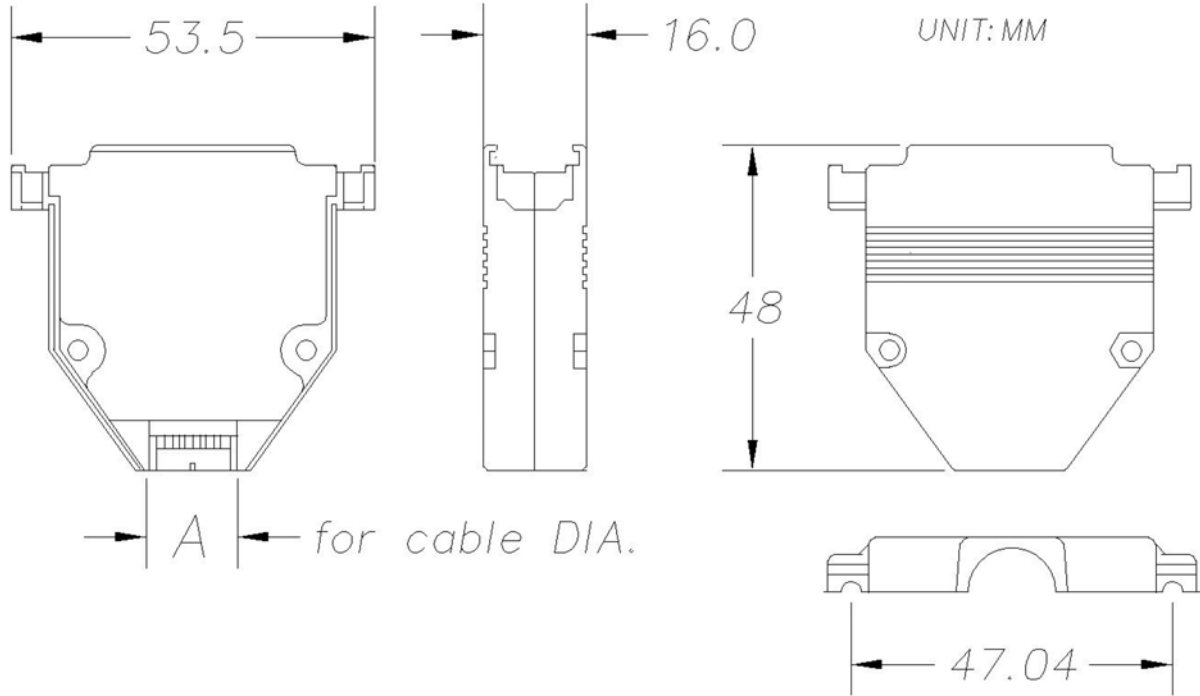

A: 7, 9, 10, 11, 13,

Series	Type	Hood	Hardware
DBS25	DV	PC	XX
25 Pos. back shell	Type DV	PC=Metalized Plastic	SS=Standard Screw TS=Metal Thumb Screw

RoHS compliant

Rev.	Description	Date	Approved	Drawing	Name	Date
				Approved	Howard	03/20/09
				Checked	Lizzy	03/20/09
				Drawn	Tina	03/20/09
				0.0 ± 0.35	0.00 ± 0.20	Angles ± 3'
						UNIT: mm

Central Components Manufacturing
 440 Lincoln Blvd., Middlesex, New Jersey 08846
 Phone 732 469-5720 888 288-5152 Fax 732 469-1919

Part No.: **DBS25-DV-PC-XX**

Description: D-Sub Metal Hood

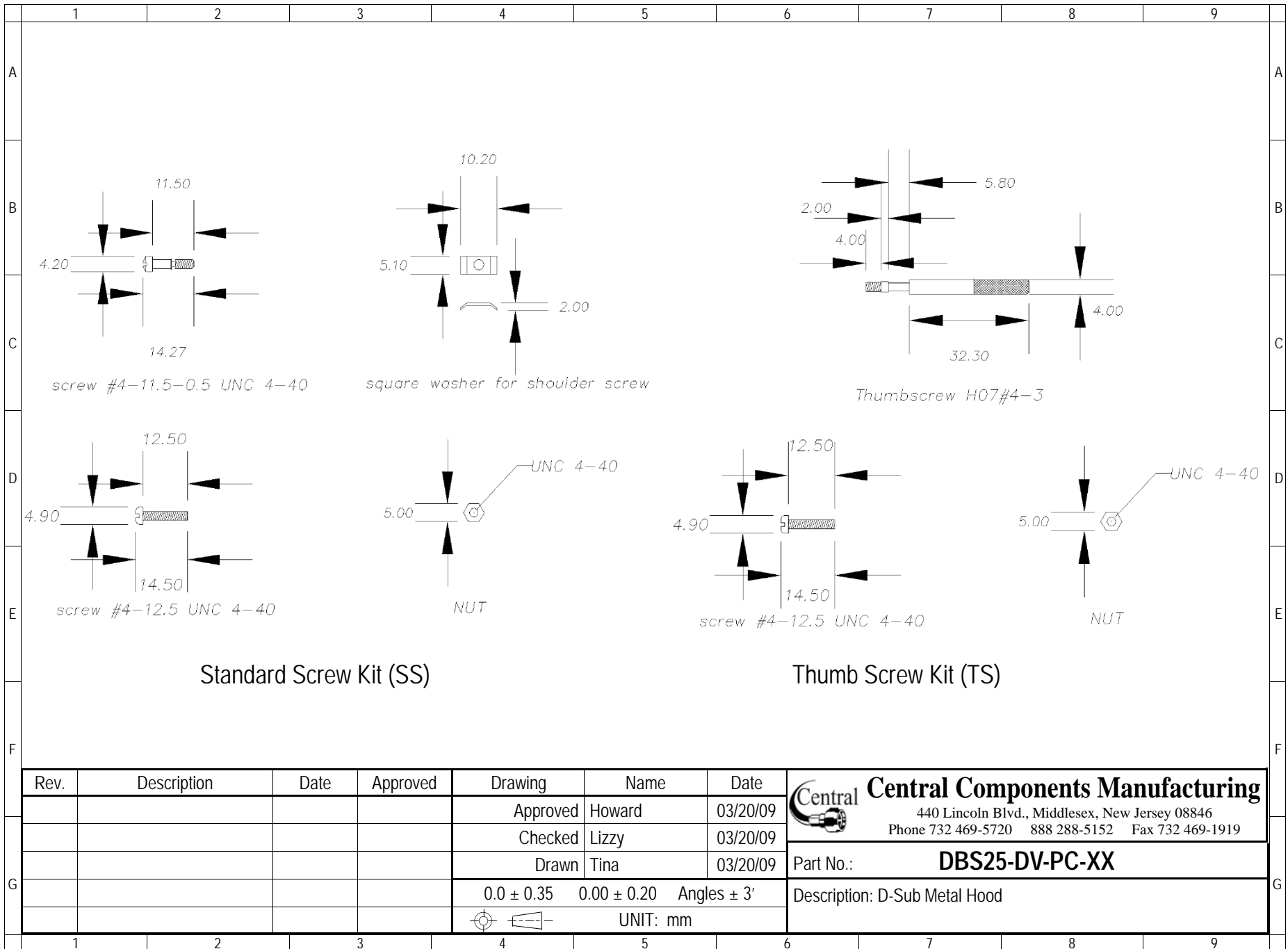

Standard Screw Kit (SS)

Thumb Screw Kit (TS)

Rev.	Description	Date	Approved	Drawing	Name	Date
				Approved	Howard	03/20/09
				Checked	Lizzy	03/20/09
				Drawn	Tina	03/20/09
				0.0 ± 0.35	0.00 ± 0.20	Angles ± 3'
						UNIT: mm
Central Components Manufacturing 440 Lincoln Blvd., Middlesex, New Jersey 08846 Phone 732 469-5720 888 288-5152 Fax 732 469-1919						Part No.: DBS25-DV-PC-XX
Description: D-Sub Metal Hood						