

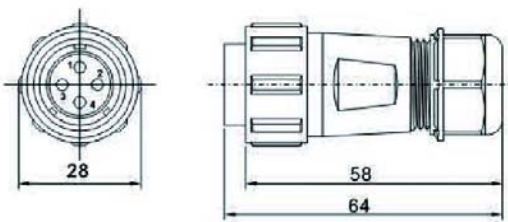





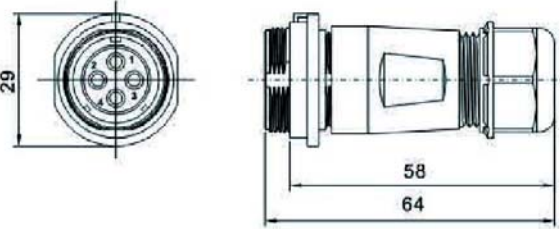
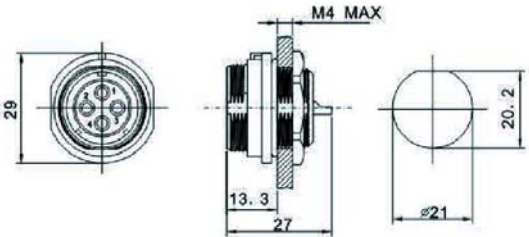
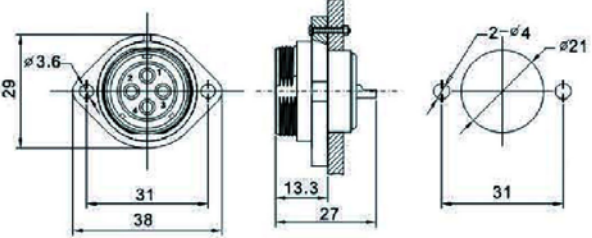

	1	2	3	4	5	6	7	8	9																												
A			<p>This item mates with CWP-SP2111, CWP-SP2112, CWP-SP2113 Threaded coupling Solder Termination.</p>																																		
B			<p>This item mates with CWP-SP2110 Threaded coupling Solder termination</p>																																		
C	<p>- CWP-SP2110-P CWP-SP2110-S</p>																																				
D			<p>This item mates with CWP-SP2110, "D" hole with a nut on the back Solder termination</p>																																		
E			<p>This item mates with CWP-SP2110, Install by screws Solder termination</p>																																		
F	<p>CWP-SP2113-P CWP-SP2113-S</p>																																				
G	<table border="1" style="width:100%; border-collapse: collapse;"> <thead> <tr> <th style="width:10%;">Rev.</th> <th style="width:30%;">Description</th> <th style="width:10%;">Date</th> <th style="width:10%;">Approved</th> <th style="width:10%;">Drawing</th> <th style="width:10%;">Name</th> <th style="width:10%;">Date</th> </tr> </thead> <tbody> <tr> <td> </td> <td> </td> <td> </td> <td> </td> <td>Approved</td> <td>Howard</td> <td>02/02/10</td> </tr> <tr> <td> </td> <td> </td> <td> </td> <td> </td> <td>Checked</td> <td>Lizzy</td> <td>02/02/10</td> </tr> <tr> <td> </td> <td> </td> <td> </td> <td> </td> <td>Drawn</td> <td>Tina</td> <td>02/02/10</td> </tr> </tbody> </table>					Rev.	Description	Date	Approved	Drawing	Name	Date					Approved	Howard	02/02/10					Checked	Lizzy	02/02/10					Drawn	Tina	02/02/10	 <p>Central Components Manufacturing 440 Lincoln Blvd., Middlesex, New Jersey 08846 Phone 732 469-5720 888 288-5152 Fax 732 469-1919</p>		<p>Part No.: CWP-SP21XX-X-XX-X</p>	
Rev.	Description	Date	Approved	Drawing	Name	Date																															
				Approved	Howard	02/02/10																															
				Checked	Lizzy	02/02/10																															
				Drawn	Tina	02/02/10																															
					<p>0.0 ± 0.35 0.00 ± 0.20 Angles ± 3'</p>  <p>UNIT: mm</p>		<p>Description: Circular Waterproof Connector</p>																														
1	2	3	4	5	6	7	8	9																													