

SPECIFICATIONS

Shield material: Stainless steel
 Housing material: Thermoplastic, UL94V-0
 Contact material: Phosphor bronze
 Contact plating: Gold over nickel

Optional panel latch
 PL=With latch
 NPL=No latch

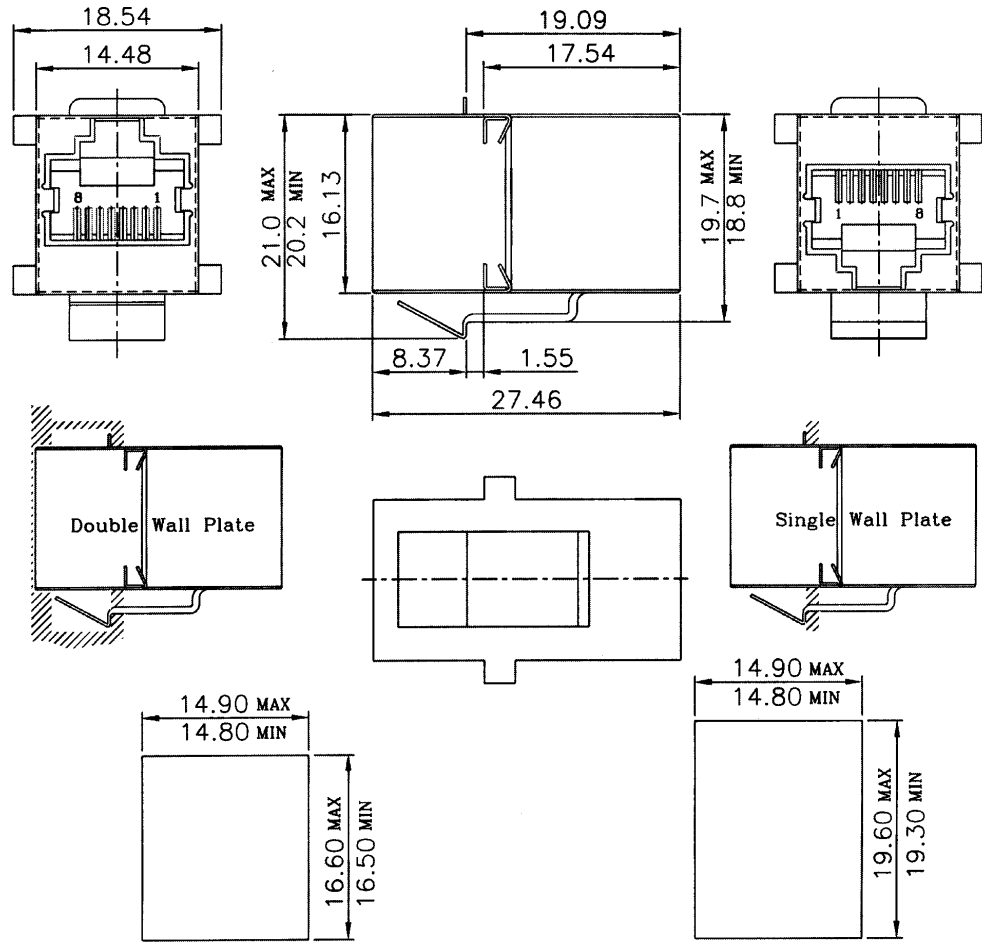

Front Panel Jack Only Clearance
 W/O Latch Feature

Single Panel-Latch Clearance
 Panel Thickness 0.062 inch

RoHS compliant

Rev.	Description	Date	Approved	Drawing	Name	Date
				Approved	Howard	08/10/99
				Checked	Lizzy	08/10/99
				Drawn	Tina	08/10/99
				0.0 ± 0.35	0.00 ± 0.20	Angles ± 3'
					UNIT: mm	

Central Components Manufacturing
 440 Lincoln Blvd., Middlesex, New Jersey 08846
 Phone 732 469-5720 888 288-5152 Fax 732 469-1919

Part No.: **CTL-CAT-018-XX-FS**

Description: Modular coupler jack, 8P8C, shielded, optional panel latch