

PC Board Layout

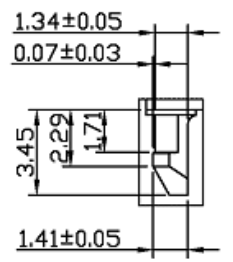

DETAIL X

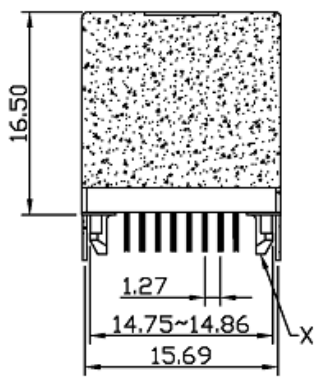
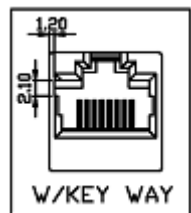

W/KEY WAY

SPECIFICATIONS

- Contact material: Phosphor bronze 0.35mm
- Contact plating: Gold on contact area  
Tin on solder tail
- Shield material: Copper alloy 0.25mm
- Shield Plating: Tin

RoHS compliant

Series	Positions	Contacts	Body Style	Ground Tab Offset	Color	Plating	Options
CTJ	8	XX	D2HP	E1	BK	PX	FS
Modular phone jack	8 positions	06=6 contacts 08=8 contacts	Style D2 HP=Half peg	E1=-3.85	BK=Black	P1=15µ" gold P2=30µ" gold P3=50µ" gold	[blank]=None FS=Full shield KY=Keyed

Rev.	Description	Date	Approved	Drawing	Name	Date
				Approved	Howard	08/10/99
				Checked	Lizzy	08/10/99
				Drawn	Tina	08/10/99
				0.0 ± 0.35	0.00 ± 0.20	Angles ± 3°
				UNIT: mm		

**Central Components Manufacturing**  
 440 Lincoln Blvd., Middlesex, New Jersey 08846  
 Phone 732 469-5720 888 288-5152 Fax 732 469-1919

Part No.: **CTJ-8-XX-D2HP-EI-BK-FS**

Description: Modular phone jack, 8 position, shielded, top entry, flangeless version