

PC Board Layout

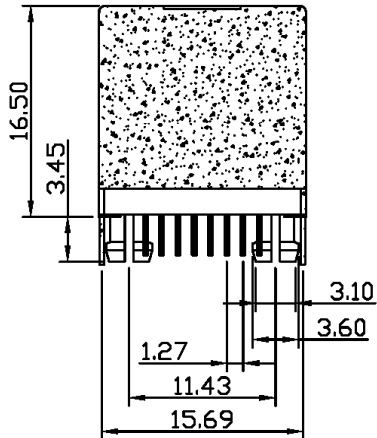

SPECIFICATIONS

- Contact material: Phosphor bronze 0.35mm
- Contact plating: Gold in contact area
Gold flash in solder tail area
- Housing material: PBT polyester, mixed glass fiber, UL94V-0, black
- Shield material: Copper alloy 0.25mm
- Shield plating: Nickel

RoHS compliant

Series	Positions	Contacts	Body	Ground Tab	Color	Plating	Options
CTJ	8	08	260	B2	BK	PX	XX
Modular phone jack	8=8 positions	08=8 contacts	260 body, vertical entry	B2=3.85mm ground tab offset	BK=Black	P1=15µ" gold P2=30µ" gold P3=50µ" gold	FS=Full shield WF=Without flange KY=With key way

Rev.	Description	Date	Approved	Drawing	Name	Date
				Approved	Howard	05/15/07
				Checked	Lizzy	05/15/07
				Drawn	Tina	05/15/07
				0.0 ± 0.35	0.00 ± 0.20	Angles ± 3°
				UNIT: mm		

Central Components Manufacturing
 440 Lincoln Blvd., Middlesex, New Jersey 08846
 Phone 732 469-5720 888 288-5152 Fax 732 469-1919

Part No.: **CTJ-8-08-260-B2-BK-PX-FS-WF**

Description: Modular jack, 8P8C, shielded, top entry, no flange