

1. CRIMPED FERRULE
HEX CRIMP SIZE .178" (4.52mm)

2. CRIMPED CONTACT PIN
HEX CRIMP SIZE .068" (1.72mm)

3. MAX. PANEL THICKNESS=3.5mm

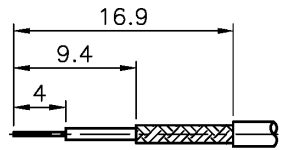

RECOMMENDED
CABLE STRIPPING DIM'S

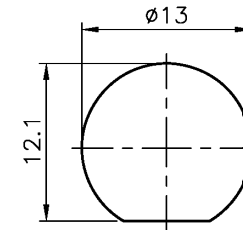

RECOMMENDED
MOUNTING HOLE

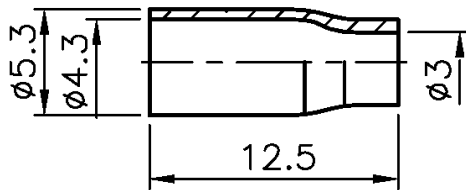
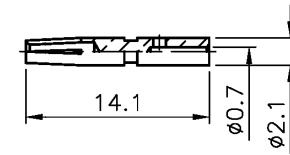
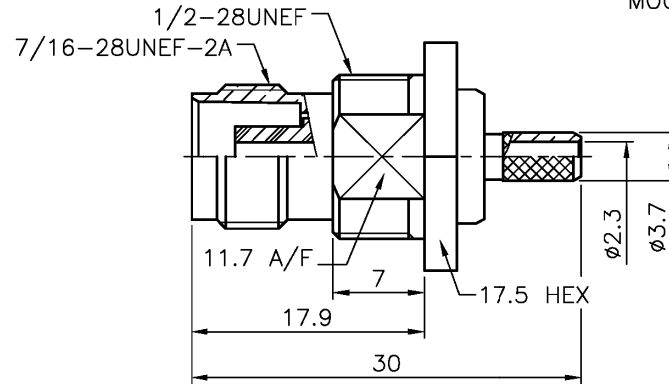
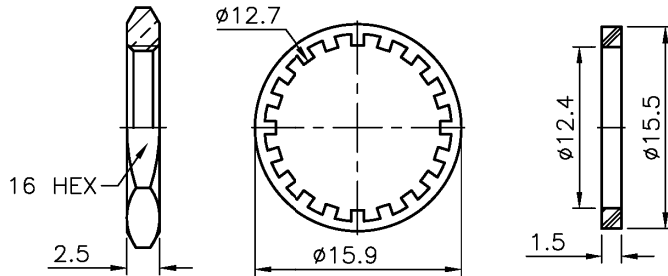

Name	Material	Finish
Nut	Brass	Nickel PL 70 min thick over copper strike
Washer	SS41	Nickel PL 70 min thick over copper strike
Gasket	Rubber	Orange
Ferrule	Brass	Nickel PL 70 min thick over copper strike
Contact Pin	Brass	Gold PL 3 min over Nickel pl 70 min thick over Copper strike
Braid Holder	Brass	Nickel PL 70 min thick over copper strike
Insulator	Teflon	White
Body	Brass	Nickel PL 70 min thick over copper strike
Hex Body	Brass	Nickel PL 70 min thick over copper strike

RoHS compliant

Rev.	Description	Date	Approved	Drawing	Name	Date
				Approved	Howard	03/29/07
				Checked	Lizzy	03/29/07
				Drawn	Tina	03/29/07
				0.0 ± 0.35	0.00 ± 0.20	Angles ± 3'
				UNIT: mm		

Central Components Manufacturing
440 Lincoln Blvd., Middlesex, New Jersey 08846
Phone 732 469-5720 888 288-5152 Fax 732 469-1919

Part No.: **CRF-TNC-7461DS-509BF001-B**

Description: TNC Bulkhead Crimp Jack (for RG-174/U,188A/U,316,U)