

RECOMMENDED  
CABLE STRIPPING DIM'S

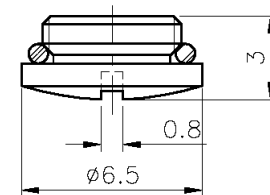
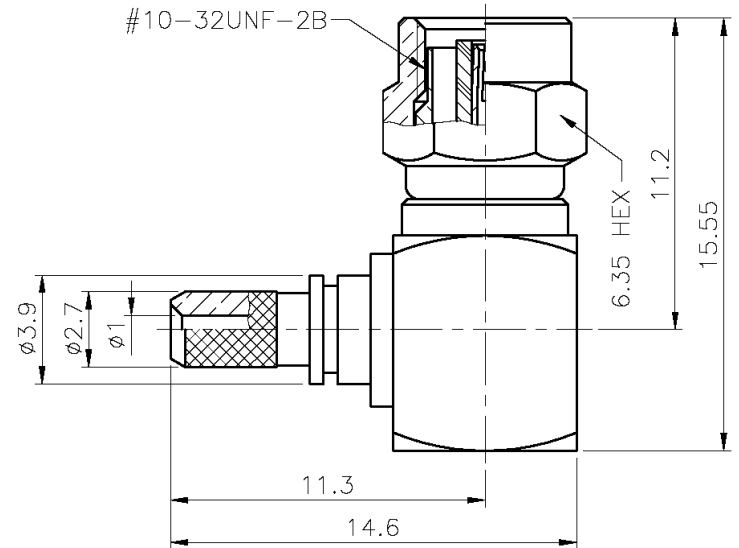
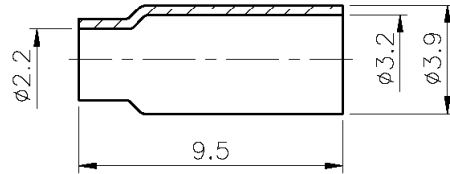

Item	Name	Material	Finish
1	Main body	Brass per QQ-B-626	Gold 3μ" over nickel 70μ" over copper
2	Insulator	Teflon MIL-P-19468	White
3	Contact pin	Beryllium copper per QQ-C-530	Gold 30μ" over nickel 70μ" over copper
4	Gasket	Silicone	Red
5	Shell	Brass per QQ-B-626	Gold 3μ" over nickel 70μ" over copper
6	Ferrule	Brass JIS H 3250, C 2700	Gold 3μ" over nickel 70μ" over copper
7	Cover	Brass per QQ-B-626	Gold 3μ" over nickel 70μ" over copper
8	Gasket	Silicone	Red

1. Crimped ferrule hex crimp size .128" (3.25mm)
2. Contact pin to solder

RoHS compliant

Rev.	Description	Date	Approved	Drawing	Name	Date
				Approved	Howard	06/20/06
				Checked	Lizzy	06/20/06
				Drawn	Tina	06/20/06
				0.0 ± 0.35	0.00 ± 0.20	Angles ± 3'
				UNIT: mm		

**Central Components Manufacturing**  
 440 Lincoln Blvd., Middlesex, New Jersey 08846  
 Phone 732 469-5720 888 288-5152 Fax 732 469-1919

Part No.: **CRF-SMC-9804-28BGTG001-R**

Description: SMC right angle crimp plug, waterproof