

RECOMMENDED
CABLE STRIPPING DIM'S

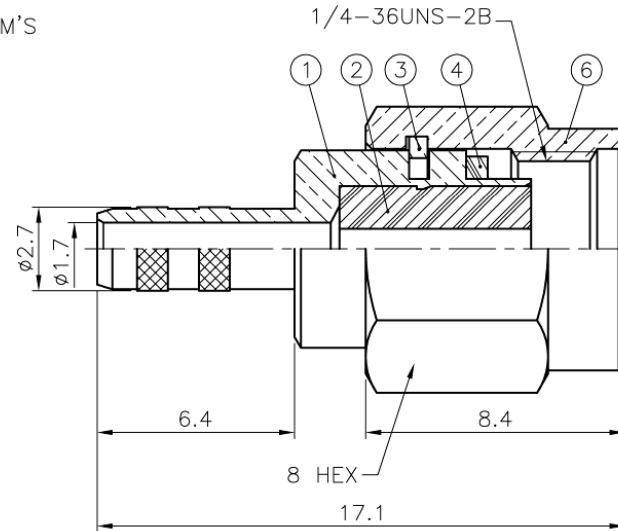
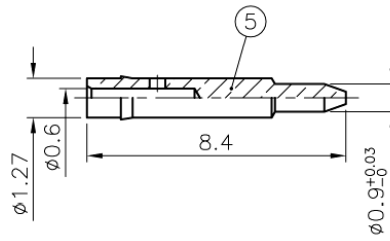
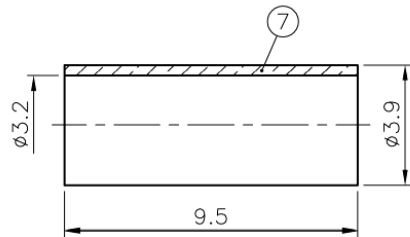

Item	Name	Material	Finish
1	Body	Brass	Gold 3 μ " over nickel 70 μ " over copper
2	Insulator	Teflon	Gold 3 μ " over nickel 70 μ " over copper
3	C ring	Beryllium copper	None
4	Gasket	Silicone	Red
5	Contact pin	Brass	Gold 30 μ " over nickel 70 μ " over copper
6	Shell	Brass	Gold 3 μ " over nickel 70 μ " over copper
7	Ferrule	Brass	Gold 3 μ " over nickel 70 μ " over copper

RoHS compliant

Rev.	Description	Date	Approved	Drawing	Name	Date
				Approved	Howard	04/15/04
				Checked	Lizzy	04/15/04
				Drawn	Tina	04/15/04
				0.0 ± 0.35	0.00 ± 0.20	Angles ± 3'
						UNIT: mm

Central Components Manufacturing
 440 Lincoln Blvd., Middlesex, New Jersey 08846
 Phone 732 469-5720 888 288-5152 Fax 732 469-1919

Part No.: **CRF-SMA-7801-BGTGD09**

Description: Waterproof SMA crimp plug for RG-174/U, RG-188A/U and RG316/U