

RECOMMENDED
CABLE STRIPPING DIM'S

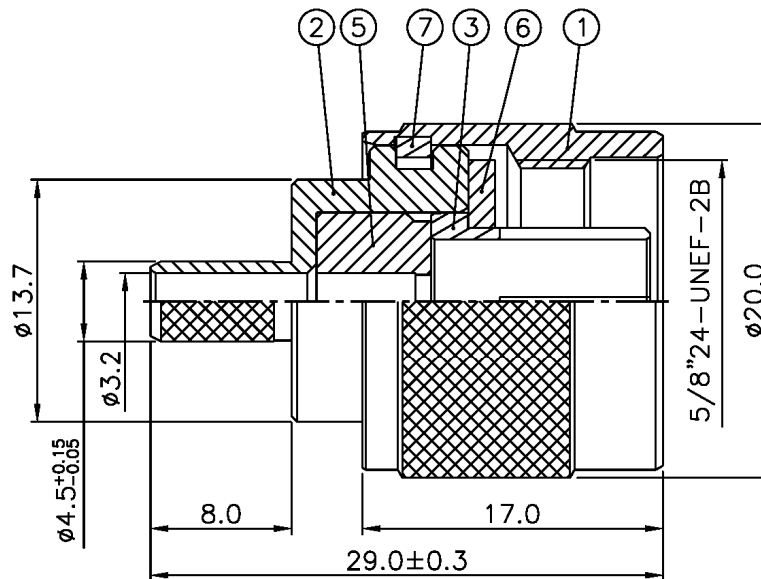
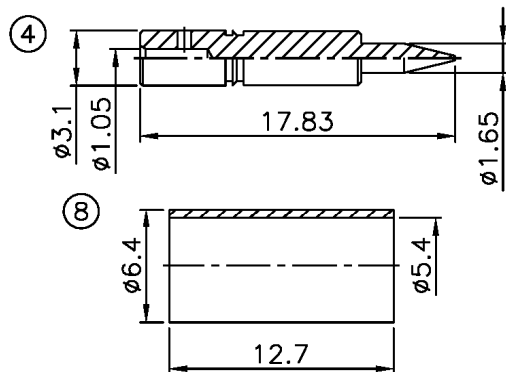

Item	Name	Material	Finish
1	Shell	Brass per QQ-B-626	Nickel 80 μ " over copper strike
2	Body	Brass per QQ-B-626	Nickel 80 μ " over copper strike
3	Body	Brass per QQ-B-626	Nickel 80 μ " over copper strike
4	Contact pin	Brass per QQ-B-626	Gold 3 μ " over nickel 70 μ " over copper strike
5	Insulator	Teflon MIL-P-19468	Natural
6	Gasket	Rubber	Red
7	Washer	Brass per QQ-B-626	None
8	Ring	Brass per QQ-B-626	Nickel 80 μ " over copper strike

RoHS compliant

Rev.	Description	Date	Approved	Drawing	Name	Date
				Approved	Howard	05/06/00
				Checked	Lizzy	05/06/00
				Drawn	Tina	05/06/00
				0.0 ± 0.35	0.00 ± 0.20	Angles ± 3'
						UNIT: mm

Central Components Manufacturing
 440 Lincoln Blvd., Middlesex, New Jersey 08846
 Phone 732 469-5720 888 288-5152 Fax 732 469-1919

Part No.: **CRF-N9348-A**

Description: N male crimp for RG58/U and LMR-195