

5/8-24UNEF-2B

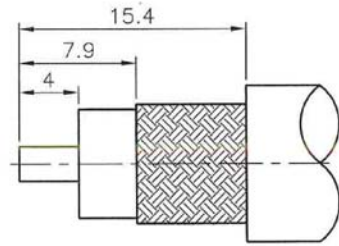
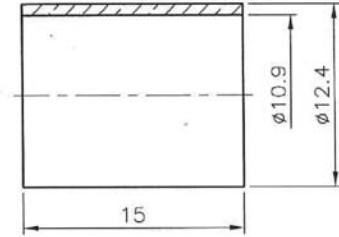
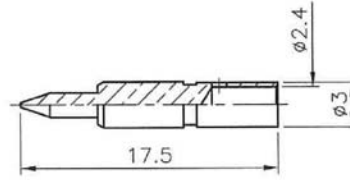
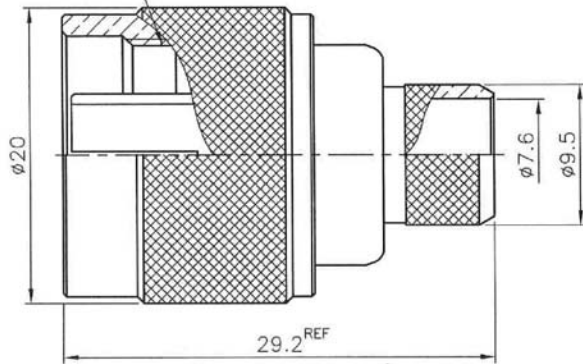

RECOMMENDED  
CABLE STRIPPING DIM'S

Crimped Ferrule  
Hex Crimp Size .429" (10.9mm)  
Crimped Contact Pin  
Hex Crimp Size .100" (2.54mm)

Item	Name	Material	Finish
1	Body	Brass	Nickel over Copper
2	Contact Body	Nickel over Copper	Nickel over Copper
3	Insulator	Teflon	White
4	Braid Holder	Brass	Nickel over Copper
5	Gasket	Silicone	Orange
6	C Ring	Brass	Nickel over Copper
7	Shell	Brass	Nickel over Copper
8	Contact Pin	Brass	Gold over Nickel over Copper
9	Ferrule	Brass	Nickel over Copper

RoHS compliant

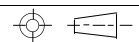
Rev.	Description	Date	Approved	Drawing	Name	Date
				Approved	Howard	11/26/08
				Checked	Lizzy	11/26/08
				Drawn	Tina	11/26/08
				0.0 ± 0.35	0.00 ± 0.20	Angles ± 3'
				 UNIT: mm		

**Central Components Manufacturing**  
 440 Lincoln Blvd., Middlesex, New Jersey 08846  
 Phone 732 469-5720 888 288-5152 Fax 732 469-1919

Part No.: **CRF-N-7311NS-513BF000B**

Description: N Crimp Plug for RG-213/U,B8267