

RECOMMENDED MOUNTING HOLE
MAXIMUM PANEL THICKNESS: 5.5MM

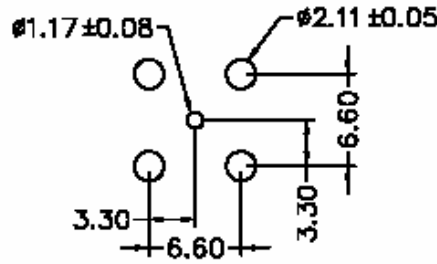

RECOMMENDED PCB BOARD LAYOUT
WITHOUT MOUNTING POSTS

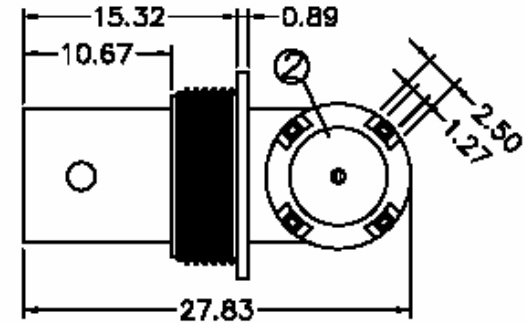

Item	Name	Material	Finish
1	Body	Zinc alloy	Nickel
2	Insulator	Teflon	
3	Insulator	TPX	
4	Center contact	Phosphor bronze	Tin
5	Center contact	Phosphor bronze	Gold

RoHS compliant

Rev.	Description	Date	Approved	Drawing	Name	Date
				Approved	Howard	08/10/99
				Checked	Lizzy	08/10/99
				Drawn	Tina	08/10/99
				0.0 ± 0.35	0.00 ± 0.20	Angles ± 3'
				UNIT: mm		



Central Components Manufacturing

440 Lincoln Blvd., Middlesex, New Jersey 08846
Phone 732 469-5720 888 288-5152 Fax 732 469-1919

Part No.: **CRF-BNC-7BR-L54N-B**

Description: BNC jack, 75 ohms, right angle, PCB mount