

SPECIFICATIONS

Insulator Material: PE606
 Body: Zinc Alloy, Nickel Plating
 Contact Material: Bronze, Gold Plating

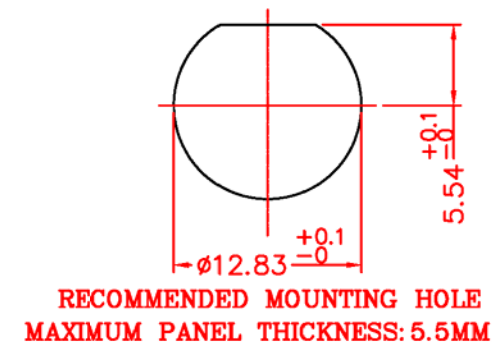
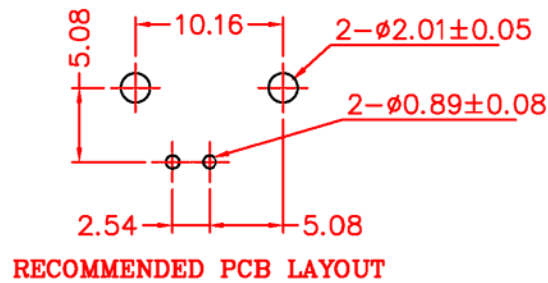

RoHS compliant

Rev.	Description	Date	Approved	Drawing	Name	Date
				Approved	Howard	03/14/94
				Checked	Lizzy	03/14/94
				Drawn	Tina	03/14/94
				0.0 ± 0.35	0.00 ± 0.20	Angles ± 3°
				UNIT: mm		

Central Components Manufacturing
 440 Lincoln Blvd., Middlesex, New Jersey 08846
 Phone 732 469-5720 888 288-5152 Fax 732 469-1919

Part No.: **CRF-BNC-7BR-01431-75**

Description: BNC Connector Right Angle, Female PCB Mount