

RECOMMENDED  
CABLE STRIPPING DIM'S

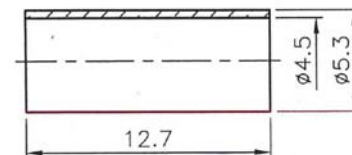
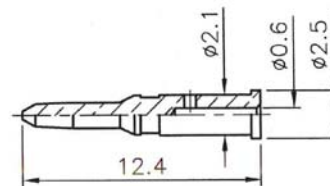
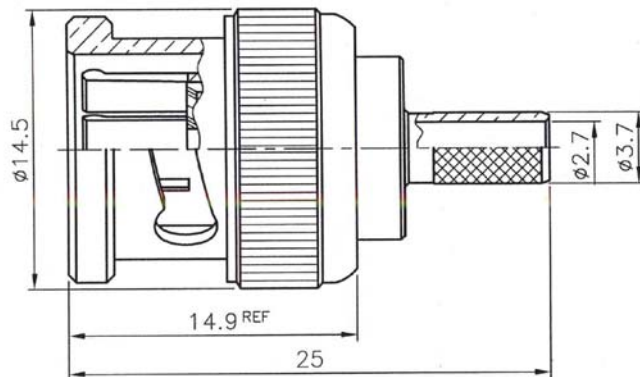

Item	Name	Material	Finish
1	Body	Brass	Nickel over Copper
2	Insulator	Delrin	White
3	Washer	SS41	Nickel over Copper
4	Spring	SK5	Nickel over Copper
5	C Ring	SS41	Nickel over Copper
6	Gasket	Silicone	Red
7	Shell	Zinc Diecast	Nickel over Copper
8	Contact Pin	Brass	Gold over Nickel over Copper
9	Ferrule	Brass	Nickel over Copper

1. Crimped Ferrule:  
Hex Crimp Size .178" (4.52mm)
2. Crimped Contact Pin:  
Hex Crimp Size .068" (1.72mm)

RoHS compliant

Rev.	Description	Date	Approved	Drawing	Name	Date
				Approved	Howard	10/30/08
				Checked	Lizzy	10/30/08
				Drawn	Tina	10/30/08
				0.0 ± 0.35	0.00 ± 0.20	Angles ± 3'
					UNIT: mm	

**Central Components Manufacturing**  
 440 Lincoln Blvd., Middlesex, New Jersey 08846  
 Phone 732 469-5720 888 288-5152 Fax 732 469-1919

Part No.: **CRF-BNC-7011NS-731ZF001B**

Description: BNC Crimp Plug 75 ohms, for  
 B8s18,B1865A,B1417B,B1164B