

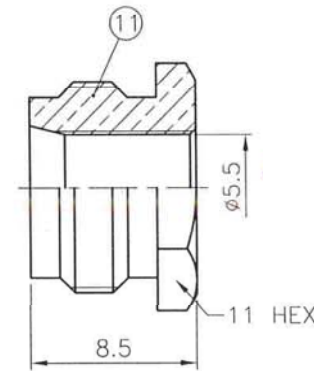

Item	Name	Material	Finish
1	Body	Brass Per QQ-B-626	Nickel PL70 Min Thick over Copper Strike
2	Washer	SS41	Nickel PL 70 Min Thick over Copper Strike
3	Spring	SK5	Nickel PL 70 Min Thick over Copper Strike
4	C Ring	SS41	Nickel PL 70 Min Thick over Copper Strike
5	Gasket	Rubber	Red
6	Shell	Brass Per QQ-B-626	Nickel PL 70 Min Thick over Copper Strike
7	Insulator	Delrin	Natural
8	Braid Holder	Brass Per QQ-B-626	Gold PL Flush Min over Nickel PL 70 Min Thick over Copper Strike
9	Insulator	Delrin	White
10	Contact Pin	Brass Per QQ-B-626	Gold PL Flush Min over Nickel PL 70 Min Thick over Copper Strike
11	Nut	Brass Per QQ-B-626	Nickel PL 70 Min Thick over Copper Strike



RoHS compliant

Rev.	Description	Date	Approved	Drawing	Name	Date
				Approved	Howard	12/29/05
				Checked	Lizzy	12/29/05
				Drawn	Tina	12/29/05
				0.0 ± 0.35	0.00 ± 0.20	Angles ± 3'
				UNIT: mm		



Central Components Manufacturing
440 Lincoln Blvd., Middlesex, New Jersey 08846
Phone 732 469-5720 888 288-5152 Fax 732 469-1919

Part No.: **CRF-BNC-7008-BNDGA**

Description: BNC Clamp Plug
(for RG-58/U, RG-58C/U)