

RECOMMENDED
CABLE STRIPPING DIM'S

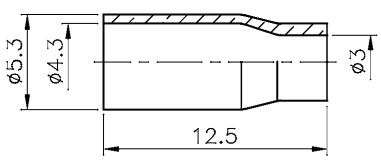
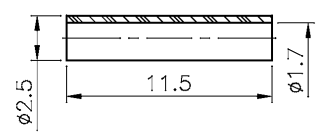
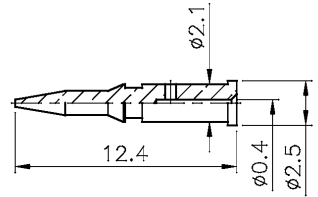
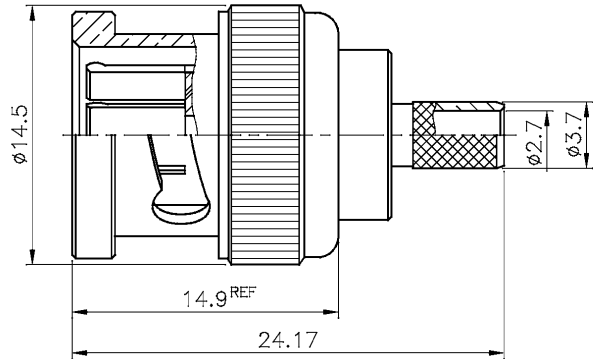

Ferrule hex crimp size: 0.178"
Contact pin hex crimp size: 0.068

Name	Material	Finish
Body	Brass	Nickel 70μ" over copper
Insulator	Delrin	White
Washer	SS41	Nickel 70μ" over copper
Spring	SK5	Nickel 70μ" over copper
C Ring	SS41	Nickel 70μ" over copper
Gasket	Rubber	Red
Shell	Brass	Nickel 70μ" over copper
Contact pin	Brass	Gold 3μ" over nickel 70u" over copper
Spacer	Delrin	White
Ferrule	Brass	Nickel 70μ" over copper

RoHS compliant

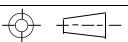
Rev.	Description	Date	Approved	Drawing	Name	Date
				Approved	Howard	12/19/05
				Checked	Lizzy	12/19/05
				Drawn	Tina	12/19/05
				0.0 ± 0.35	0.00 ± 0.20	Angles ± 3'
				 UNIT: mm		

Central Components Manufacturing
 440 Lincoln Blvd., Middlesex, New Jersey 08846
 Phone 732 469-5720 888 288-5152 Fax 732 469-1919

Part No.: **CRF-BNC-7001-11BNDG001-R**

Description: BNC crimp plug, 75 ohm; for RG-179/U and RG-187A/U