

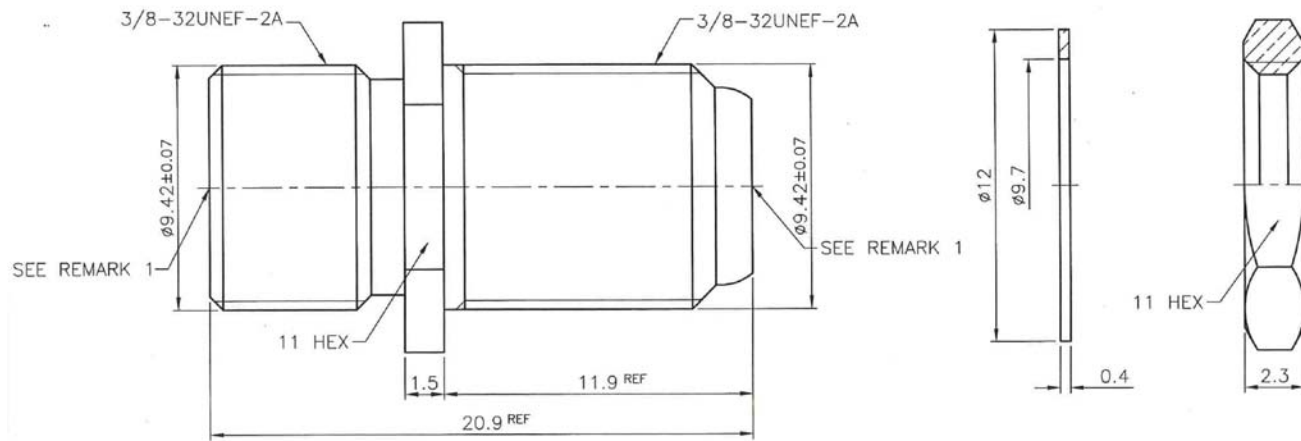

Accepts  $\varnothing 0.5 \sim \varnothing 1.07$  Mating Pin



Item	Name	Material	Finish
1	Body	Brass Per 11-B-626	Nickel PL 70 Min Thick over Copper
2	Insulator	P.P.	Natural
3	Contact Pin	Brass JIS H 3100, C 2680	Bright Tin PL 100 Min Thick over Copper
4	Washer	SS41	Nickel PL 70 Min Thick over Copper
5	Nut	Steel	Nickel PL 70 Min Thick over Copper

RoHS compliant

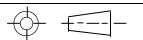
Rev.	Description	Date	Approved	Drawing	Name	Date	 <b>Central Components Manufacturing</b> 440 Lincoln Blvd., Middlesex, New Jersey 08846 Phone 732 469-5720 888 288-5152 Fax 732 469-1919 Part No.: <b>CRF-7278AS-700CL000B</b> Description: F Jack to Bulkhead Jack Adaptor
				Approved	Howard	08/07/08	
				Checked	Lizzy	08/07/08	
				Drawn	Tina	08/07/08	
				$0.0 \pm 0.35$ $0.00 \pm 0.20$ Angles $\pm 3'$  UNIT: mm			