

**SPECIFICATIONS**

Operating voltage: 50 volts  
 Current rating: 0.5 amps  
 Contact material: Phosphor bronze  
 Contact plating: Tin or gold over nickel  
 Contact resistance: 30 milliohms max.  
 Insulation resistance: 500 megohms min.  
 Housing material: Glass-filled Nylon46, UL94V-0, white  
 Withstanding: 500VAC rms for 1 min.  
 Fitting material: Bronze  
 Fitting plating: Tin alloy  
 Operating temperature: -55°C to +85°C

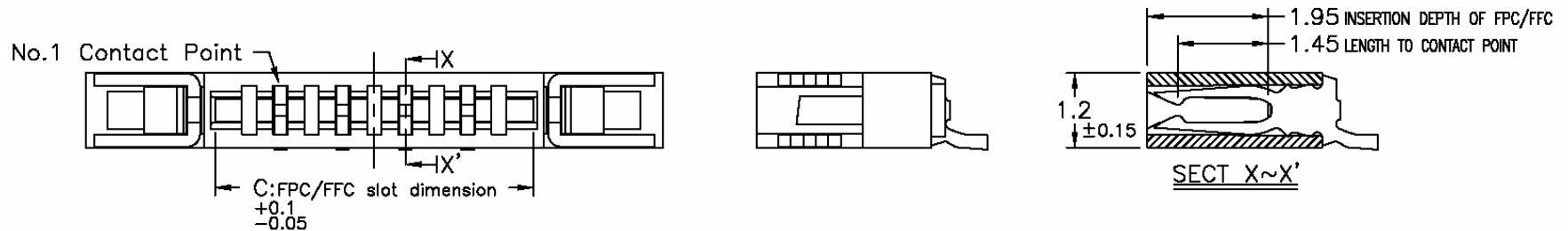

Series	Pitch	Type	Contacts	Style	Plating	Options
CFPC	100	S118	XX	RUB	TN	XX
FPC connector	100=1.00mm 030=0.30mm 050=0.50mm 125=1.25mm	S118 type	4-24 (See table, p. 2)	R=Right angle V=Vertical U=Upper contacts B=Bottom contacts	TN=Tin over nickel	[blank]=None TR=Tape & reel TB=Tube

RoHS compliant

Rev.	Description	Date	Approved	Drawing	Name	Date
				Approved	Howard	02/20/02
				Checked	Lizzy	02/20/02
				Drawn	Tina	02/20/02
				0.0 ± 0.35	0.00 ± 0.20	Angles ± 3'
				UNIT: mm		

**Central Components Manufacturing**  
 440 Lincoln Blvd., Middlesex, New Jersey 08846  
 Phone 732 469-5720 888 288-5152 Fax 732 469-1919

Part No.: **CFPC-100-S118-XX-RUB-TN-XX**

Description: FPC connector, 1.00mm pitch, LIF type, right angle SMT, upper and lower contact type

# PCB Layout

Dimensions							
Pos.	A	B	C	Pos.	A	B	C
4	9.25	3.0	5.1	15	20.25	14.0	16.1
5	10.25	4.0	6.1	16	21.25	15.0	17.1
6	11.25	5.0	7.1	17	22.25	16.0	18.1
7	12.25	6.0	8.1	18	23.25	17.0	19.1
8	13.25	7.0	9.1	19	24.25	18.0	20.1
9	14.25	8.0	10.1	20	25.25	19.0	21.1
10	15.25	9.0	11.1	21	26.25	20.0	22.1
11	16.25	10.0	12.1	22	27.25	21.0	23.1
12	17.25	11.0	13.1	23	28.25	22.0	24.1
13	18.25	12.0	14.1	24	29.25	23.0	25.1
14	19.25	13.0	15.1				

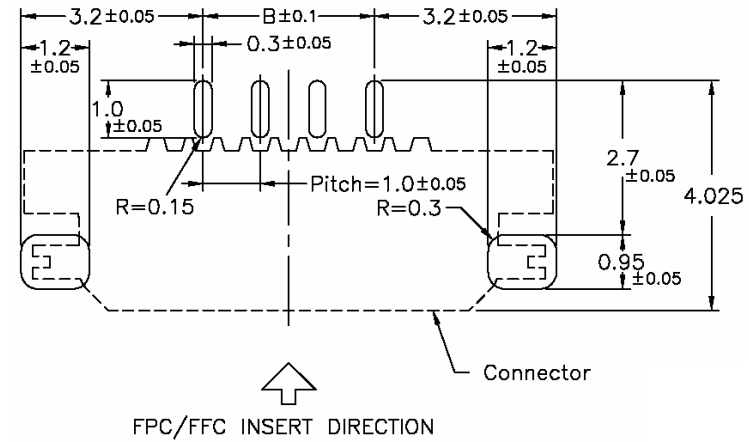

## Applicable FPC

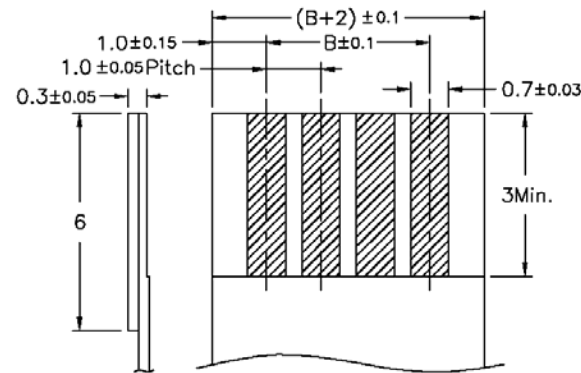

RoHS compliant

Rev.	Description	Date	Approved	Drawing	Name	Date
				Approved	Howard	02/20/02
				Checked	Lizzy	02/20/02
				Drawn	Tina	02/20/02
				0.0 ± 0.35	0.00 ± 0.20	Angles ± 3'
				UNIT: mm		

**Central Components Manufacturing**  
 440 Lincoln Blvd., Middlesex, New Jersey 08846  
 Phone 732 469-5720 888 288-5152 Fax 732 469-1919

Part No.: **CFPC-100-S118-XX-RUB-TN-XX**

Description: FPC connector, 1.00mm pitch, LIF type, right angle SMT, upper and lower contact type