

SPECIFICATIONS

Sleeve material: Brass, machined
 Sleeve plating: Gold or tin
 Clip material: Phosphor bronze
 Clip plating: Gold or tin

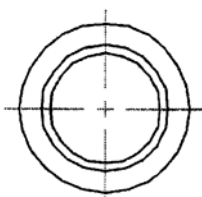
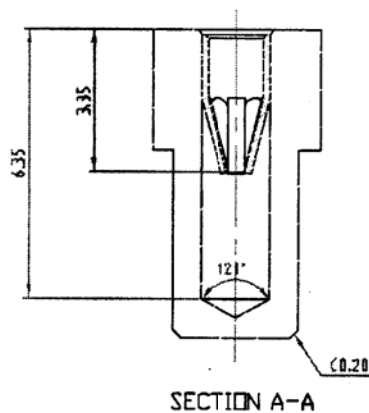
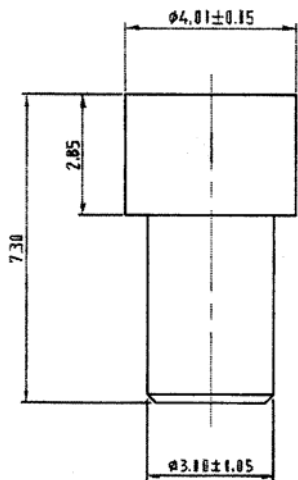

Series	Style	Plating
CCT	0027	XX
Receptacle	0027=Closed sleeve 0027A=feed through sleeve	TN=20μ" tin plated sleeve and clip GD*=Gold flash on sleeve and clip SG*=Gold plated clip, tin plated sleeve *10μ" or 30μ" may be added for thicker gold plating

RoHS compliant

Rev.	Description	Date	Approved	Drawing	Name	Date
				Approved	Howard	08/10/02
				Checked	Lizzy	08/10/02
				Drawn	Tina	08/10/02
				0.0 ± 0.35	0.00 ± 0.20	Angles ± 3'
						UNIT: mm

Central Components Manufacturing
 440 Lincoln Blvd., Middlesex, New Jersey 08846
 Phone 732 469-5720 888 288-5152 Fax 732 469-1919

Part No.: **CCT-0027-XX**

Description: 7.3mm pin connector