

SECTION A-A

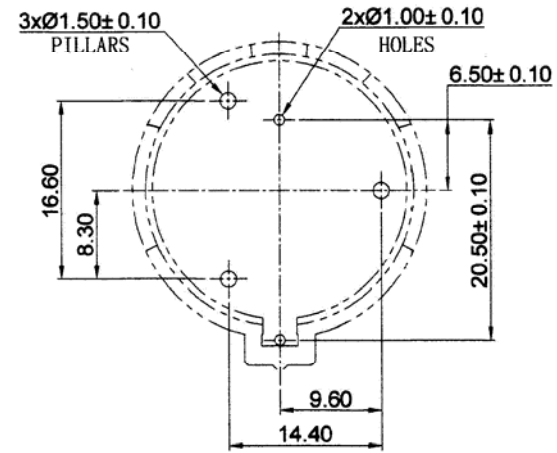



PCB MOUNTING LAYOUT

**SPECIFICATIONS**

Current Rating: 3A  
 Voltage Rating: 500V  
 Housing Material: Nylon 66 UL94V-0, Black  
 Contact Material: Phosphor Bronze, Tin Plating over Nickel  
 Contact Resistance: 100 Milliohms  
 Insulation Resistance: 100 Megaohms  
 Temperature Range: -40°C to +105°C  
 Humidity: 40°C and 90-95% RH for 96 Hours

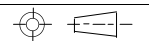
RoHS compliant

Rev.	Description	Date	Approved	Drawing	Name	Date
				Approved	Howard	03/25/08
				Checked	Lizzy	03/25/08
				Drawn	Tina	03/25/08
				0.0 ± 0.35	0.00 ± 0.20	Angles ± 3'
						UNIT: mm
 <b>Central Components Manufacturing</b> 440 Lincoln Blvd., Middlesex, New Jersey 08846 Phone 732 469-5720 888 288-5152 Fax 732 469-1919						Part No.: <b>BTH-CH002-2425</b> Description: Coin Cell Holder